

GOK





Assembly instructions – Compression fittings

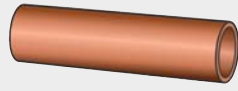

Assembly instructions - Compression fittings

acc. to EN ISO 8434-1 / DIN 2353 with reference to DIN 3859-2 and DIN 3387-1

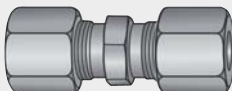
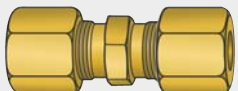
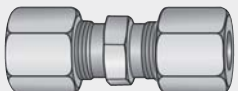
Pipe: design, dimensions and recommended material type	Steel Precision steel pipe or pipe sockets, dimensions acc. to EN 10305 Parts 1-4, 6	Copper and wrought copper alloy - Copper pipe EN 1057 - GOK brass brazed nipple - brass pipe made from CW614N, CW617N	Stainless steel Stainless steel pipe, dimensions acc. to EN 10305-1 or EN ISO 1127 dimension tolerances D4 and T4 X6CrNiMoTi17-12-2 acc. to EN 10088-3
			
Compression fitting: material mating	St Steel Olive design steel or brass	MS Brass Olive design brass	X Stainless steel Olive design stainless steel
			
D	Direct assembly in screw socket		V
		Pre-assembly in the VOMO pre-assembly tool socket and final assembly in screw socket	

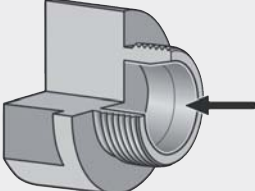
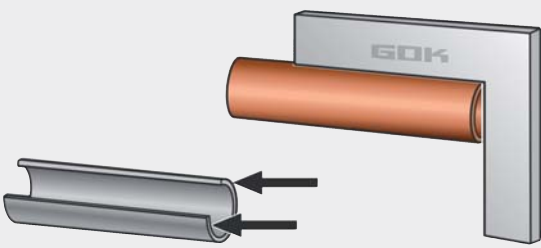
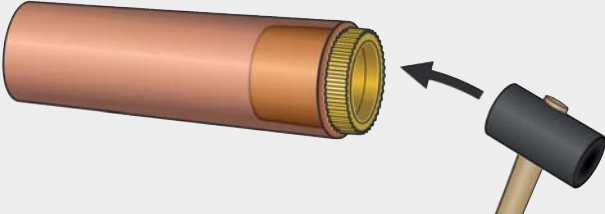
	VOMO cones are subject to wear. Therefore, check accuracy to gauge regularly (approx. after every 50th pre-assembly) with a cone gauge. Replace VOMOs that are not accurate to gauge or which are showing signs of wear to prevent incorrect assembly.	V
	Saw pipes at a right angle. An angle tolerance of 0.5° is permitted. Do not use a pipe cutter or an angle grinder. Slightly deburr the inside and outside of the pipe ends. Maximum permitted bevel 0.2 x 45°. Then clean the pipe. NOTE: Shape deviations at the end of the pipe, such as pipes sawn at an angle or incorrectly deburred, reduce the life and leakproofness of the connection.	D V
	For all seamless, thin-wall pipes and soft pipe materials (e.g. copper or aluminium): Insert a reinforcing sleeve into the pipe to the edge of the knurl. Tap the reinforcing sleeve completely into the pipe with a hammer (plastic or rubber). This presses the collar of the knurl against the inside of the pipe and prevents the sleeve moving or falling out.	D V

Assembly instructions - Compression fittings

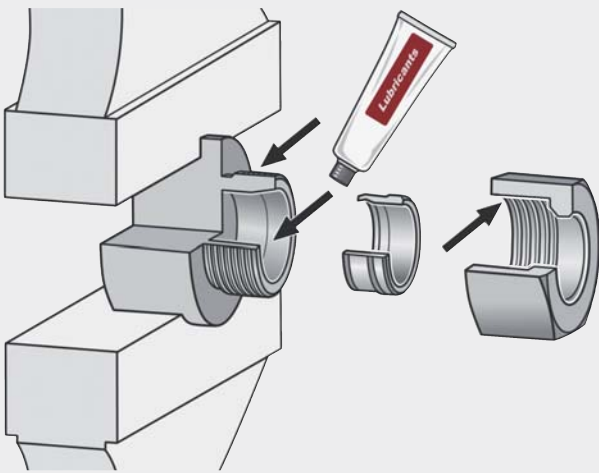
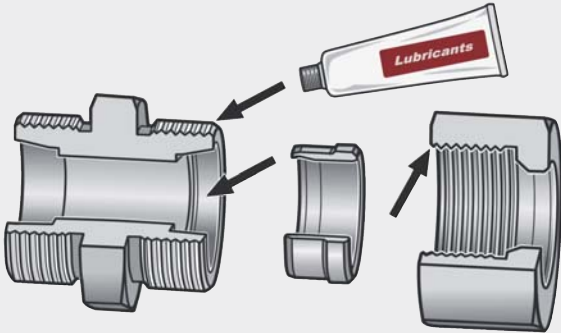
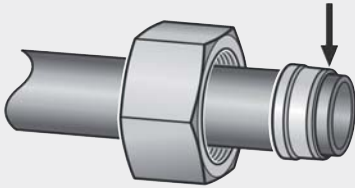
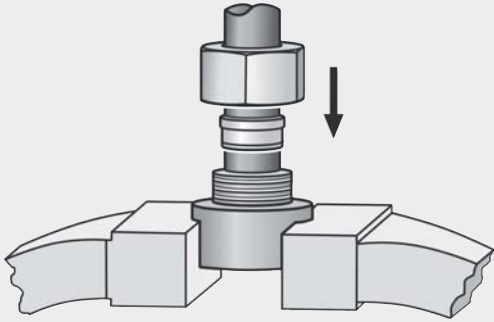
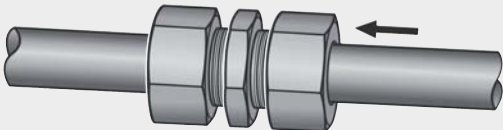
	<p>Place the VOMO pre-assembly tool for the selected pipe in the vice. Lubricate the thread and cone of the VOMO and the thread of the coupling nut. Screw the coupling nut onto the VOMO loosely so that the lubricant can spread more evenly.</p>	V
	<p>Slightly oil the thread and cone of the screw socket and the thread of the coupling nut (e.g. lubricant, not grease). NOTE: There is no need to oil zinc-plated pipe joints with a transparent anti-friction coating.</p>	D V
	<p>Slide the coupling nut and then the olive on to the pipe with the cutting edge facing the end of the pipe. NOTE: Make sure that the olive sits properly → otherwise incorrect assembly.</p>	D V
	<p>Tighten the coupling nut by hand until you feel that the VOMO, olive and coupling nut are pressed together. Press the pipe against the end stop in the VOMO.</p>	V
	<p>Tighten the coupling nut by hand until you feel that the screw socket, olive and coupling nut are pressed together. Press the pipe against the end stop in the screw socket. NOTE: The pipe must touch the end stop, otherwise the pipe will not be cut.</p>	D

Assembly instructions - Compression fittings

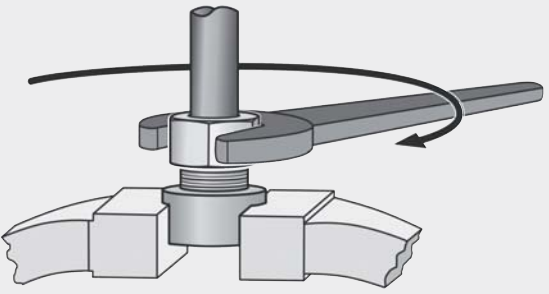
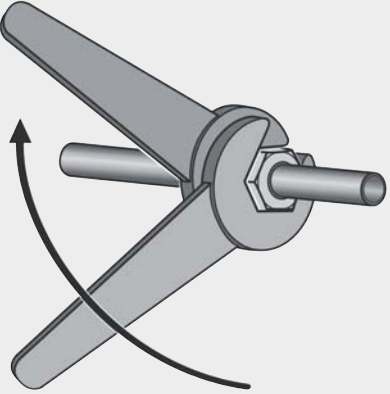
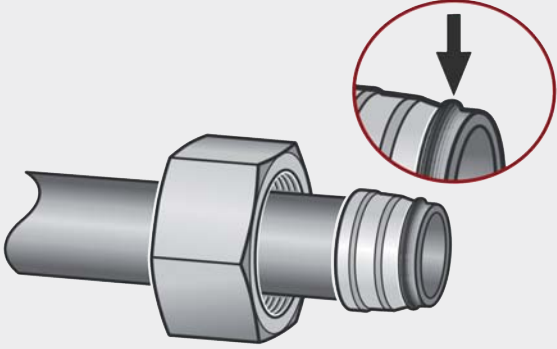
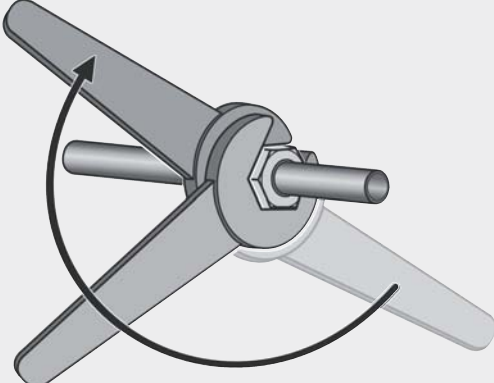
	<p>Pre-assembly in the VOMO: Tighten the coupling nut by 1 - 1 1/2 turns (depending on the dimensions and material). Hold the VOMO in place with an open-end spanner.</p>	V
	<p>Initial assembly: Tighten the coupling nut by approx. 1 1/2 turns. Hold the screw socket in place with an open-end spanner.</p> <p>The pipe must not rotate.</p> <p>NOTE: If the screw is not properly tightened, this will reduce the pressure-bearing capacity and life of the screwed joint. This may cause leaks or the pipe may slide out.</p>	D D V
<p>Collar: Partly visible pipe material collar</p> 	<p>Check: Dismantle the pipe connection by loosening the coupling nut.</p> <p>VOMO pre-assembly tool: The collar in front of the first, front cutting edge must be even and cover 80% of the cutting face.</p> <p>NOTE: With stainless steel pipes there is no collar on the cutting edge as there is with steel pipes. Stainless steel olives sit relatively loosely on the pipe.</p> <p>With STEEL: The collar must completely fill the cutting face. The olive may turn but it must not be possible to move it in an axial direction.</p>	D V V D
	<p>Final assembly in the screw socket with the VOMO: Tighten the coupling nut by hand until you feel that the screw socket, olive and coupling nut are pressed together. Tighten the coupling nut 1/4 to 1/2 turn more than the point at which you feel the pressure increase; hold the screw socket in place with an open-end spanner.</p> <p>Factory-installed olives: Tighten the coupling nut 1/4 - 1/3 turn.</p> <p>NOTE: If the screw is not properly tightened, this will reduce the pressure-bearing capacity and life of the screwed joint. This may cause leaks or the pipe may slide out.</p>	V

Assembly instructions - Compression fittings

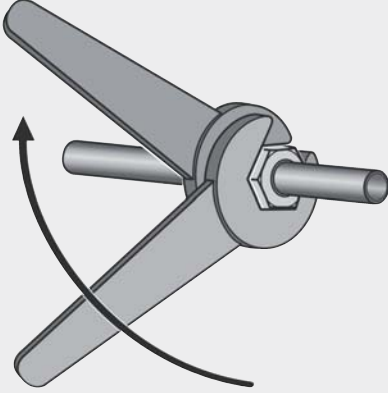
	<p>Repeat assembly: Each time you loosen the pipe connection, you must tighten the coupling nut again (same force) the same as in final and initial assembly; hold the screw socket in place with an open-end spanner.</p>	<p>D V</p>
<p>Leakproofness: In accordance with the applicable installation and construction regulations for piping, it is recommended that the leakproofness of every screwed joint is tested after assembly with test and/or operating medium under test and/or operating pressure; e.g. with foaming material according to EN 14291. Field of applicability DIN 3387-1: Compression fittings for all gases acc. to DVGW Worksheet G 260. [DVGW: German Technical and Scientific Association for Gas and Water]</p>		<p>D V</p>

⚠ WARNING

- Dismantling and/or tightening of screwed joints and screwed parts is permitted only when they are not under any pressure.
- The use of compression fittings is subject to the respective installation regulations, such as DVGW-TRGI, TRF.