

**LOW PRESSURE SWITCH-ON BUTANE REGULATOR
MODEL : 700G**

**OPERATING INSTRUCTIONS TO BE KEPT BY THE USER
READ THOROUGHLY BEFORE USE**

INSTRUCTION FOR USE

These Installation and Operating Instructions are to be kept for future reference.

Please read the instructions carefully before connecting the regulator to the cylinder valve or operating any appliance.

This regulator is only designed for Butane 20/21/22 mm Switch-on cylinder valves. DO NOT force the regulator on to the cylinder valve. If problems are encountered, consult your dealer.

TECHNICAL INFORMATION

Type of Gas	:	Butane
Capacity	:	1000 g/h
Maximum Inlet Pressure	:	7.5 bar
Nominal Outlet Pressure	:	29 mbar
Permitted downstream	:	$\Delta P2$
Pressure drop		
Inlet Connection	:	20/21/22 mm Switch-on type
Outlet Connection	:	Suitable for connection to 8/10 mm inside diameter hose
Temperature Limitations	:	Between 0°C to + 50°C
Specification	:	EN 16129 & CE 610716

OPERATING INSTRUCTIONS

1. Fitting and Operating Conditions

The "Low pressure switch-on regulator" is a domestic regulator designed to supply gas to consuming appliances at a pressure and capacity as indicated on the identification label (1).

The "switch-on regulator" can be fitted to any cylinder equipped with automatic valves having a diameter as indicated on the regulator (2). (Fig. 1)

The gas cylinder must always be used in the upright position.

When the device is to be used outdoors, the "Switch-On" regulator must be protected against penetration of rain or trickling water.

In case of any difficulties or problems, turn the gas supply OFF and immediately contact your dealer.

Never move or displace the gas cylinder when it is on.

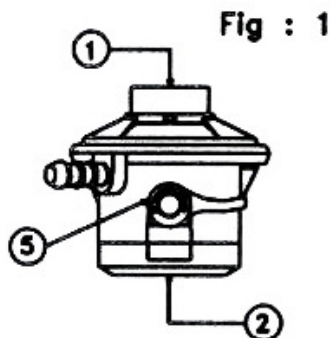

2. Fitting the Hose

Before connecting the "Switch-On" regulator to a cylinder valve, take care to fit a regulation rubber hose (3) to the barbed stem (lubricate the latter with water to facilitate the insertion). To guarantee a

sound connection, use a regulation hose clip (4), which is usually sold together with the hose and is in any case matched with the hose dimensions. (Fig : 2)

Fig : 2

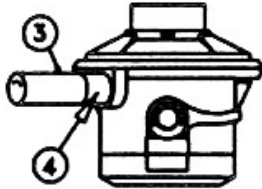

3. Assembly on the gas Cylinder

Make sure that :

1. All taps of the consuming appliance are closed;
2. The connecting hose to the consuming appliance is correctly fitted;
3. The "Switch-On" regulator handle is in the "OFF" position (Fig : 4)

With no flame on, remove the seal cap from the automatic cylinder valve, place the "Switch-On" regulator on to the valve and push down firmly and vertically.

You should hear a "Click" sound which means the regulator is securely latched (Fig : 3).

Notes : The "Switch-On" regulator is so designed as to prevent it from being fitted to the valve, unless the regulator handle is in the "OFF" position; therefore, never attempt to mount or dismount it, when the handle is not in "OFF" position.

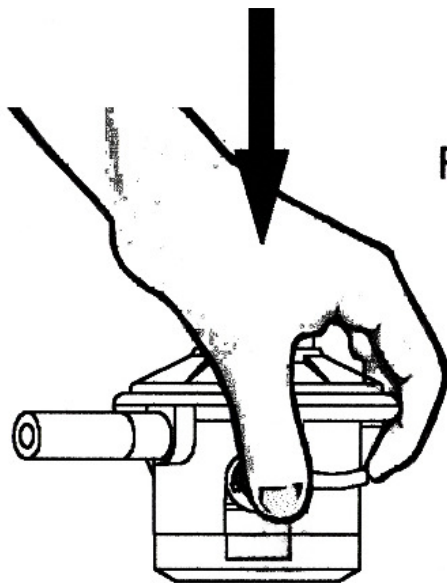

Fig : 3

4. Operation

Once the "Switch-On" regulator is correctly mounted on the valve, gas supply is possible by turning the regulator handle (5) upwards (anticlockwise)

To shut OFF the gas supply, reverse the above Procedure (Clockwise); an arrow engraved on the handle indicates the closing direction.(Fig : 4)

Fig : 4

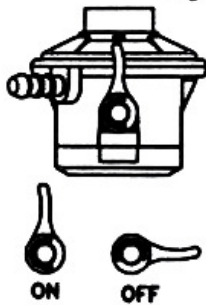

Caution : If you are unable to turn the regulator handle to the “ON” position, this means that your “Switch-On” regulator is not correctly connected to the valve. Do not force the handle to open, and restart the operations described under 3) above.

5. Replacement of a Cylinder

Make sure that :

1. All taps of the gas consuming appliance are in the “OFF” position;
2. The “Switch-On” regulator handle (5) is in the “OFF” position;

Then, dismantle the “Switch-On” regulator by pressing horizontally on the handle (5) and pulling upwards at the same time (Fig. 5)

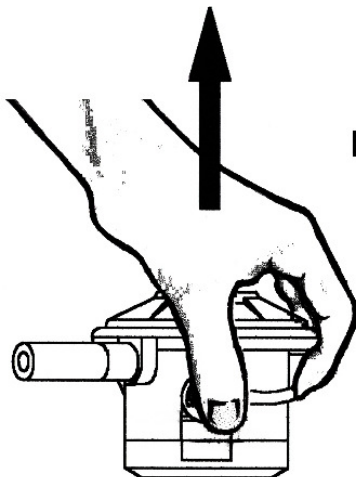

Fig : 5

General

1. Ensure that your gas equipment is maintained in sound condition. Consult your Dealer if you are in any doubt as to the safety or efficiency of your gas equipment.
2. When using fuel-burning equipment (especially in confined spaces) make sure there is ADEQUATE VENTILATION.
3. NOTIFY YOUR DEALER whenever you require service. This regulator cannot be adjusted. Any attempt to do so will invalidate the warranty.
4. Make certain that you know how to operate all the equipment and appliances.
5. NEVER fit a cylinder on its side or leaning out of the vertical. ALWAYS upright, with the valve uppermost.
6. The regulator must only be used in horizontal position with the adjuster/regulator bonnet facing upwards or vertical position with the outlet facing downwards.
7. NEVER allow anyone other than a person experienced in the operation to connect or disconnect cylinders or regulators.

8. NEVER LOOK FOR GAS ESCAPES WITH A NAKED FLAME. Use a soapy water solution to trace the leak.
 9. TURN OFF THE GAS SUPPLY AND INFORM YOUR DEALER immediately if you suspect any part of your gas system to be leaking.
 10. Never use tools to operate the cylinder valve. If the valve does not operate freely, DO NOT remove the plastic valve branch cap. PUT THE CYLINDER OUTDOORS IN A SAFE WELL-VENTILATED PLACE AND INFORM YOUR DEALER IMMEDIATELY.
 11. ALWAYS fit TYPE approved appliance. NEVER use the appliances other than in the manner and circumstances laid down in the manufacturer's literature.
 12. NEVER tamper with the mechanism of the regulator.
 13. DO NOT move the cylinder during operation.
 14. When the device is to be used outdoors, it shall be protected against penetration of rain or trickling water.
 15. This regulator is not for use on road vehicles or boats.
 16. BUTANE attacks natural rubber, therefore ensure that only TYPE approved flexible hoses and special synthetic rubber low pressure tubing are used, and that only TYPE approved jointing compounds and greases are used. All nozzles for approved low pressure hoses must be of the approved type. It is recommended that all hoses be examined at frequent intervals and replaced by your dealer if there is any sign of damage or deterioration.
 17. In normal conditions, the life expectancy of the regulator is estimated as 10 years. It is recommended that the regulator is changed within 10 years of the date of manufacture.
 18. Take care to protect the surface of the doomed brass nipple of the connector from damage. If this becomes damaged notify your dealer.
 19. NEVER disconnect or attempt to disconnect the regulator from the cylinder valve if a burner remains alight.
 20. Remember, there are various sizes and types of cylinder valves on the market. ALWAYS use the correct size or type of regulator that fits your gas cylinder valve. NEVER attempt to force the connection of the regulator and cylinder valve. If you have any doubts or difficulties, please contact your dealer.
 21. WARNING - This regulator is designed for normal use indoors where it will not be subjected to rain, snow, frost etc. It may however, be sited outside where the regulator must be protected from exposure to water, i.e. rain, snow.
 22. WARNING - Butane freezes at 0°C (32°F). If this temperature is approached or reached, you may not be able to draw gas from the cylinder or suffer reduced pressure to the appliance. In this situation, turn the cylinder valve "OFF".
- To guarantee proper operation, the hose that supplies gas to the consuming appliance shall be no more than 2 meters in length.